

TRAY BODY CARE AND WARRANTY INFORMATION



TRIPLE M
TRAY BODIES®

“Quality First at the Right Price”

CARING FOR YOUR TRAY BODY

GENERAL CARE

If the tray body comes into contact with salt water or other corrosive substances, wash the body liberally with fresh water to remove the substances.

Do not allow water or organic matter to sit in the tray body for long periods of time as this may cause staining or corrosion.

Moisture can be trapped between the tray floor and tray mats or toolboxes which can lead to staining or corrosion.

Load restraint devices, rope or adhesive tape may cause damage to aluminium or painted surfaces.

GENERAL CLEANING OF YOUR TRAY BODY

When cleaning the tray body, care should be taken not to subject the aluminium, painted, zinc or galvanized surfaces to acidic or alkaline cleaners, only neutral pH products (6.5-7.5pH) should be used (refer to the product label or the MSDS).

A liberal application of water is suggested to rinse the surface after cleaning. Any damage caused by using acidic or alkaline cleaners will not be covered by warranty.

For painted surfaces on steel trays, use the same cleaning products as recommended on your vehicle's cabin.

SPARE PARTS

Spare parts are readily available for your tray body, please contact the Triple M Sales department with your tray body serial number, which is located on the tray body's main bearers.

STEP 1

DROPSIDE AND TAILGATE FITMENT

Ensure the hinge seat is clean and free from particles such as sand or grit. Place the horizontal dropside / tailgate panel down onto the hinge seats attached to the tray deck. The dropside / tailgate hinges are designed to fall into the hinge seats only in the horizontal position.

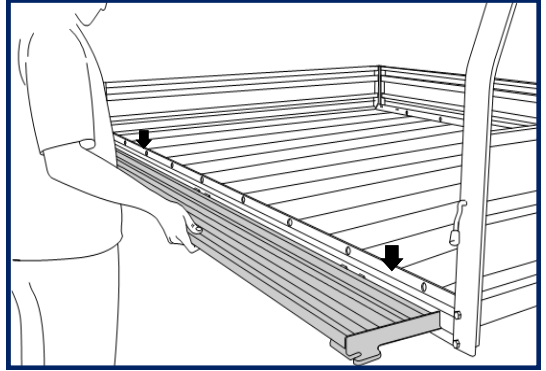

STEP 2

DROPSIDE AND TAILGATE FITMENT

Once the dropside / tailgate is sitting in the hinge seats, rotate the dropside / tailgate in an upwards direction to automatically engage the hinges into the hinge seats.

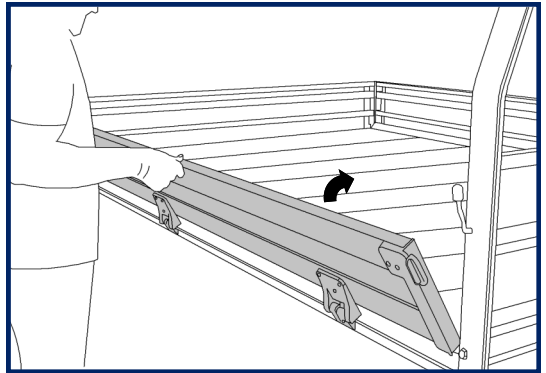

STEP 1

DROPSIDE AND TAILGATE REMOVAL

Lower the dropside / tailgate to a horizontal position. Apply inward pressure to the dropside / tailgate in order to disengage the hinges from the hinge seats.

Once all hinges are disengaged from the hinge seats, the dropside / tailgate can be lifted up and away from the tray body.

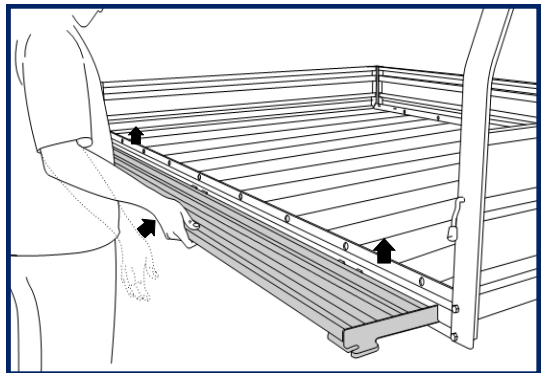

TRIPLE M
TRAY BODIES

STEP 1

LATCH ADJUSTMENT

Shake closed dropside to detect the firmness of the latch.

If the latch is too tight or the dropside rattles, place spanner on the lock nut behind headboard as shown in the diagram adjacent.

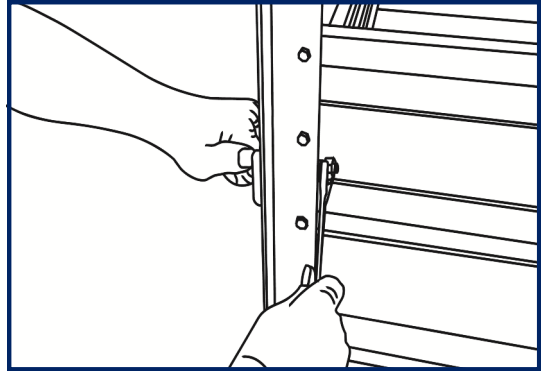

STEP 2

LATCH ADJUSTMENT

Turn the dropside latch clockwise to tighten or anti-clockwise to loosen until correct adjustment is achieved as shown in the diagram adjacent.

The latch should operate easily while holding the dropsides firmly in position.

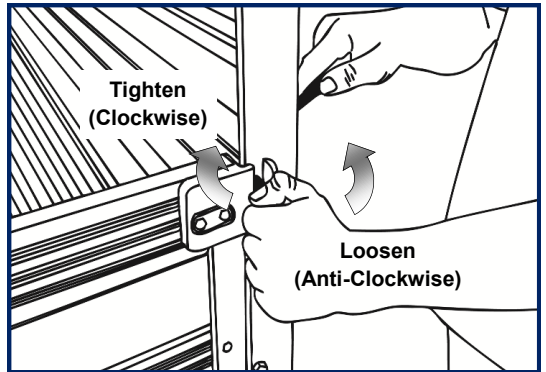

STEP 3

LATCH ADJUSTMENT

Repeat Steps 1 and 2 at the rear of the tray body for tailgate latch adjustment.

Re-adjust accordingly until there is no discernible movement when the dropside is shaken and the latch is still easy to operate.

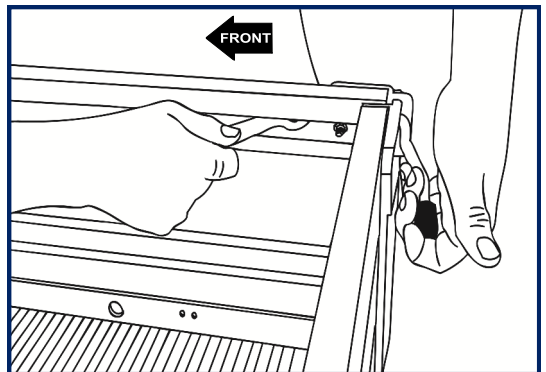

STEP 1

LADDER RACK FITMENT

Engage the ladder rack socket into the key on one side of the body.

By applying pressure, push the ladder rack inward of tray allowing the socket to clear the key, then drop downward to engage the socket over the key.

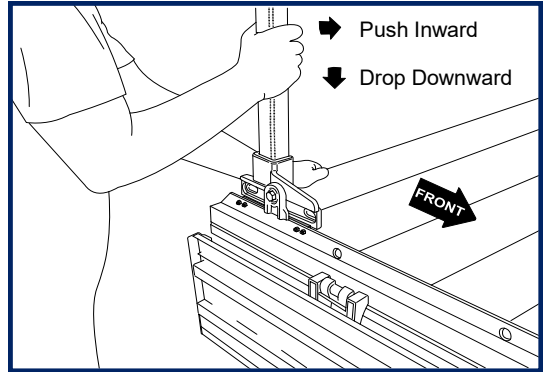

STEP 2

LADDER RACK FITMENT

Tighten the M12 lock plate on the outer side of the ladder rack socket firm against the tray body coaming (or socket mount plate) as shown in the diagram adjacent.

Repeat for opposite side.

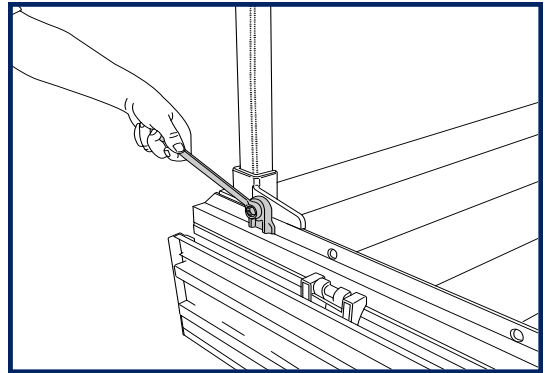

STEP 1

LADDER RACK REMOVAL

Loosen the M12 lock plate as described in Ladder Rack Fitment, Step 2.

Apply pressure to push the ladder rack inward of tray allowing the socket to clear the key, then lift the rack socket away from the key.

Repeat for opposite side.

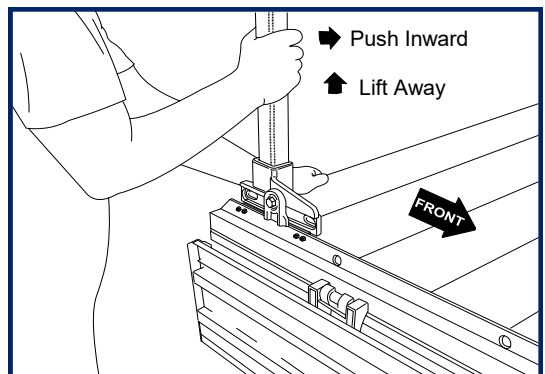

TRIPLE M
TRAY BODIES

TRAY BODY LOAD RATINGS

LADDER RACK

150kg (Unless otherwise specified on the ladder rack)

Load must be evenly distributed over the ladder rack and the tray headboard.

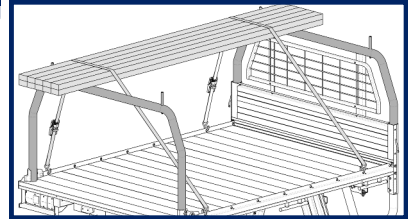

EXTERNAL ROPE RAILS

400kg

Strapping must not cause the drop sides to concave once tightened.

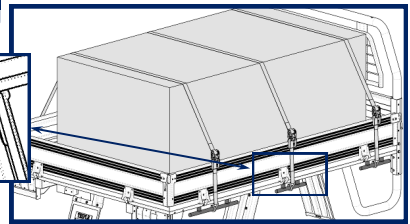
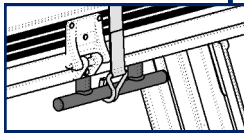

INTERNAL LOAD RESTRAINT POINTS

400kg

Eyelet \varnothing : 19mm

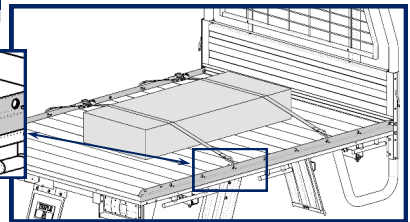
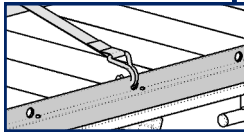

TRAY FLOOR POINT LOADING

GPA Deck	100kg
HDA Deck	100kg
Steel Deck	200kg

Load footprint area less than 25cm²

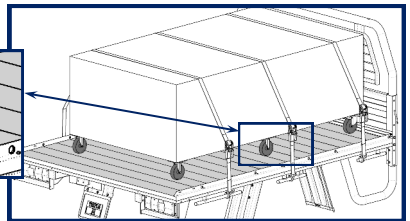
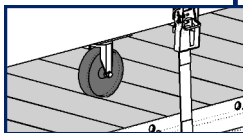

To find the payload capacity for the tray deck, refer to the vehicle manufacturers payload limits. Refer to load rating decals or fitting instructions for ratings on individual accessories.

LOAD RESTRAINT

Every driver carrying a load has a duty of care to ensure any load is adequately restrained to avoid shifting or release.

Many drivers do not believe their driving manoeuvres involve high braking or cornering forces. These diagrams demonstrate some manoeuvres that can cause a load to shift or release.

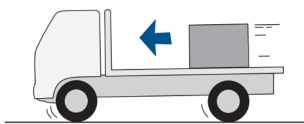

BRAKING

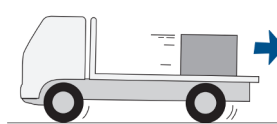

BRAKING IN REVERSE



CORNERING

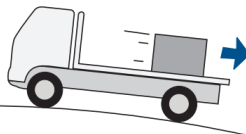
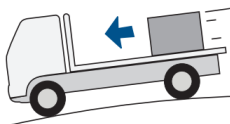

INCLINES & DECENTS

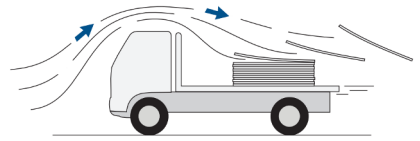

AIR FLOW

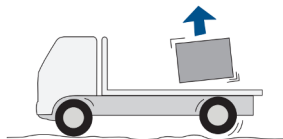

ROUGH ROADS

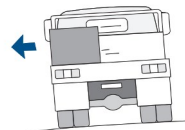

CAMBER

For further information regarding load restraint, refer to local government laws or obtain a copy of the Load Restraint Guide from the National Transport Commission.

The above information has been sourced from the NCT Load Restraint Guide

WARRANTY STATEMENT

In addition to all applicable guarantees by law, Triple M Holdings Pty Ltd offers a limited warranty against defects in materials and workmanship under normal use for a period of 3 years or 100000km, whichever occurs first. This limited warranty applies from the date of the original sale from new, purchased from Triple M Holdings Pty Ltd or its authorised resellers, provided that:

- The product has been installed as per the installation instructions.
- The supplied care instructions have been followed.
- The product has not been modified.
- The product has been used for the purpose that it was originally designed for and in accordance with the product information and relevant safety & compliance laws.
- The product has not been used in underground mining or other highly corrosive environments.
- The product has not been used in competition or racing.
- The product has not been overloaded beyond the stated load capacity or the vehicle’s legal payload.

Warranty Exclusions:

- Normal wear and tear.
- White rust on zinc plated components.
- Deterioration of rubber, plastic, zinc plating and decals having regard to the age of the vehicle, the operating conditions and the level of care given to the product during its life.
- Deterioration of aluminium, paint and plastic components caused by (including but not limited to) environmental fallout, stone pecking, hail damage, airborne fall out, scratches, sap, bird, insect and bat droppings, UV damage, oxidation, salt, harsh chemicals and adhesives.
- Damage to paint, aluminium or steel surfaces caused by tonneau covers, cargo nets, load restraints, tray mats or general loads.
- Light bulbs and reflectors.
- Surface corrosion on sheet metal part edges.
- Galvanised steel spangle texture visible in the paint finish.

Making a Claim:

To submit a claim, go to www.triplemtraybodies.com.au/warranty-application/.

Alternatively, you can contact Triple M Holdings Pty Ltd on **1800773030** or by emailing warranty@tmhpl.com.au. You must make this claim as soon as you become aware of a

possible defect in the product. You will need to complete a warranty claim form that includes your name, contact information and in the case of a tray body, the tray serial number. The claim form includes a section to attach photographic evidence of the proposed defect in support of the claim.

In the case of returning an easily transported part of a tray to Triple M Holdings for warranty assessment, the customer bears the full cost of transport. Claims involving the tray or a large component of a tray that is difficult to transport may be agreed using photographic evidence and first-hand descriptions from the owner or an authorised professional.

Warranty Remedy:

For valid warranty claims: Triple M Holdings Pty Ltd will repair or replace the product or component free of charge within a reasonable timeframe. All parts returned to Triple M Holdings Pty Ltd in relation to a validated claim will become the property of Triple M Holdings Pty Ltd unless agreed otherwise. If goods are replaced during the warranty period, the warranty on the replacement goods will expire on the same date as the original goods.

Australian Consumer Law:

The benefits provided to you the consumer by this warranty are in addition to other rights and remedies available under the law. Our goods come with guarantees that cannot be excluded under the Australian Consumer Law. You are entitled to a replacement or refund for a major failure and compensation for any other reasonably foreseeable loss or damage. You are also entitled to have the goods repaired or replaced if the goods fail to be of acceptable quality and the failure does not amount to a major failure.

Limitation of Triple M Holdings Pty Ltd liability in respect of any claim, whether under a warranty or otherwise

To the maximum permitted by the Australian Consumer Law, the liability of Triple M Holdings Pty Ltd for any claim under a warranty or otherwise will be limited, in the case of the supply of goods, to

- a) the replacement of the goods or the supply of equivalent goods;
- b) the repair of the goods;
- c) the payment of the cost of replacing the goods or of acquiring equivalent goods;
- d) the payment of the cost of having the goods repaired, and in the case of the supply of services,
- e) the supply of the services again; or
- f) the payment of the cost of having the services supplied again.

“Quality First at the Right Price”

ACCESSORIES

- 1) HDP Water Tank
- 2) HDP Toolbox with Stainless door
- 3) Ladder Rack (to suit headboard shape)
- 4) Underbody Draw
- 5) Tail Light Protectors and Wiring Guards
- 6) Window Protection options
- 7) Colour Matching (Steel Tray Only)
- 8) Tray Net
- 9) Tray Entry systems

There are even more ways to accessorise your Triple M Tray Body, including battery boxes, aerial/light mounts, extinguisher brackets and more!

Talk to our friendly Sales Department, drop them an email or simply browse through our website.

All the details are just below:

Free Call: 1800 773 030

Web: www.triplemtruckbodies.com.au

Email: sales@triplemtruckbodies.com.au



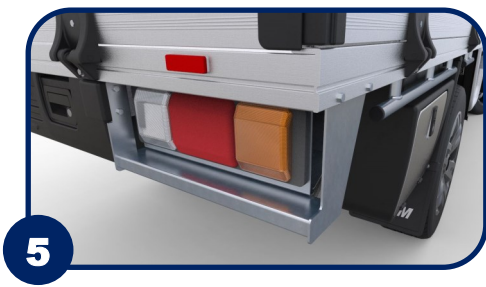

TRIPLEM
TRAY BODIES

TRIPLE M

TRAY BODIES



HEAD OFFICE:

Triple M Holdings PTY. LTD.

10 Elliot Drive

Stapylton QLD 4207

Australia

Free Call: 1800 773 030

Phone: (07) 3807 5333

Fax: (07) 3807 5151

Web: www.triplemtruckbodies.com.au

Email: sales@triplemtruckbodies.com.au

3M0374—Version 2